



STEP AP242 Benchmark



Test report for the STEP AP242 Benchmark #3

PDM test cases - Short Report

September 2020 – Version 1.0: released

Table of Contents

1	<i>Introduction</i>	5
2	<i>References and terms</i>	7
2.1	Reference documents	7
2.2	Abbreviations	7
3	<i>Test methodology</i>	8
3.1	Functionalities tested in this benchmark	8
3.2	List of tested solutions	8
4	<i>Test case NEST: PDM Assembly with 3D Geometry represented with nested files</i>	9
4.1	“Nested” / “fully shattered” approach	9
4.2	Test model overview	9
4.3	Test procedure	10
4.4	Test criteria	11
5	<i>Test case Multi-Ids</i>	13
5.1	Multi-Ids approach	13
5.2	Test model overview	14
5.3	Test procedure	15
5.4	Test criteria	16
6	<i>Tested solutions and test results</i>	19
6.1	Introduction	19
6.2	Tested solutions	20
6.3	Overview of all tests results	21
6.3.1	NEST test case results	21
6.3.2	Multi-id test case results	22
6.4	Test results by functionalities and by STEP conformity criteria	23
6.4.1	STEP functionalities	23
6.4.2	STEP conformity	23
6.4.3	Conclusion	24
7	<i>Summary</i>	25
8	<i>Publications</i>	25
9	<i>Acknowledgements</i>	25

List of figures

Figure 1	– V cycle for STEP AP242 solutions.....	5
Figure 2	– Illustration of the 3D Geometry of the dataset “AS1”	9
Figure 3	– Example of AS1 for Nested Structure	10
Figure 4	– Test procedure illustration	10

Figure 5 – "Toy car block" Test model illustration 14

Figure 6 – Test procedure illustration 15

Figure 7 – Charts of the test results by STEP functionalities and conformity criteria of the previous benchmark..... 24

Figure 8 – Charts of the test results by STEP functionalities and conformity criteria of this benchmark 24

List of tables

Table 1 – Reference documents 7

Table 2 – Test criteria of NEST test case:..... 11

Table 3 – Test criteria of Multi-Ids test case..... 16

Table 4 – Tested solution and conversions..... 20

Table 5 – Legend..... 21

Table 6 – Summary of the test results for the NEST test case 21

Table 7 – Legend..... 22

Table 8 – Summary of the test results for the Multi-id test case 22

Abstract

The STEP AP242 Benchmark is an AFNeT and prostep ivip associations project with the support of several industry associations (GIFAS, PFA).

The objective of this benchmark is to provide a public status of STEP AP242 functionalities available for operational use, tested by the industry and to identify limitations of the tested PLM COTS AP242 applications.

This Benchmark #3 includes two types of test cases: CAD and PDM test cases. This document presents the test suites of the PDM test cases.

The tests are based on exchange of PDM information, correctness and conformity of the STEP files, fulfilment of end-to-end assembly validation properties, and end-user validation. Furthermore, the test results are derived to provide conclusions on the general maturity of STEP AP242 BO Model XML based implementations, related to the main PDM functionalities.

Related websites

AP242 project: <http://www.ap242.org/>

AP242 Benchmark: <http://benchmark.ap242.org/>

PDM-IF: <http://www.pdm-if.org/>

CAX-IF: <http://www.cax-if.org/>

Disclaimer

This document is an AFNeT and prostep ivip Documentation. Those are freely available for all AFNeT and prostep ivip e.V. members. Anyone using these recommendations is responsible for ensuring that they are used correctly.

This AFNeT and prostep ivip Documentation gives due consideration to the prevailing state-of-the-art at the time of publication. Anyone using AFNeT and prostep ivip Documentation must assume responsibility for his or her actions and acts at their own risk. The AFNeT and prostep ivip Associations and the parties involved in drawing up the AFNeT and prostep ivip Documentation assume no liability whatsoever.

We request that anyone encountering an error or the possibility of an incorrect interpretation when using the AFNeT and prostep ivip Documentations contact the AFNeT and prostep ivip Associations (benchmarks@afnet.fr and psi-issues@prostep.org) immediately so that any errors can be rectified.

Copyright

- I. All rights on this AFNeT and prostep ivip Documentation, the copyright rights of use and sale such as the right to duplicate, distribute or publish the Documentation remain exclusively with the AFNeT and prostep ivip Associations and their members.
- II. The AFNeT and prostep ivip Documentation may be duplicated and distributed unchanged, for instance for use in the context of creating software or services.
- III. It is not permitted to change or edit this AFNeT and prostep ivip Documentation.
- IV. A suitable notice indicating the copyright owner and the restrictions on use must always appear.

1 Introduction

ISO 10303 STEP AP242 is available for the Automotive and Aerospace industries, as well as many other branches of the manufacturing industry, as a unique product standard for Managed model-based 3D engineering data interoperability STEP AP242 has been released as “International Standard” (IS) in August 2014 and the edition 2 is published in April 2020. Multiple COTS applications have been tested by the CAx Implementor Forum and the PDM Implementor Forum based on the 2014 AP242 edition 1.

STEP AP242 applications become increasingly important for CAD and PDM interoperability in the manufacturing industries. This project allows our communities to reach a status of maturity for these applications. The benchmarking activities are needed to apply quality control to AP242 based implementations.

Therefore, AFNeT and prostep ivip decided to conduct the STEP AP242 Benchmarks and to support the user community represented by several industry associations (GIFAS, PFA) and manufacturers which drive the project, for getting an independent assessment of COTS STEP AP242 interfaces.

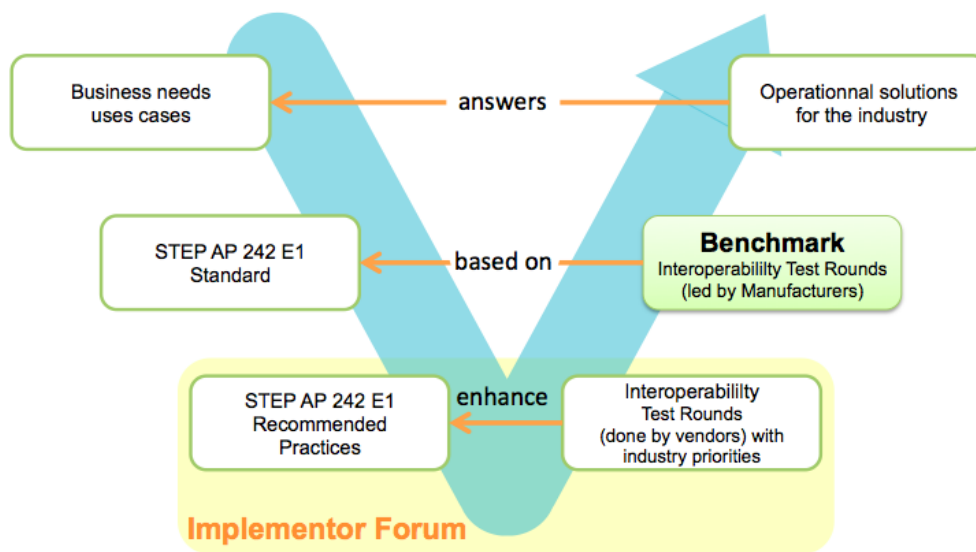

Figure 1 – V cycle for STEP AP242 solutions

The objective of this Benchmark is to provide a public status of STEP AP242 functionalities available for operational use, tested by the industry and to identify limitations of the tested PLM COTS AP242 applications.

This project is composed of two work packages:

- CAD work package managed by AFNeT;
- PDM work package managed commonly by AFNeT and prostep ivip.

The organization of this Benchmark is based on the following principles:

- business priorities defined by the industry stakeholders supporting the STEP AP242 Benchmark;
- AP242 interoperability functionalities already tested by the CAx-IF and PDM-IF;
- tests based on STEP AP242 COTS solutions available on the market or on their way to be shipped to the industry.

This document presents the test suite of the PDM test cases which cover the tests of the following AP242 PDM functionalities:

- PDM Assembly with 3D Geometry represented with **nested** files references to CAD and non-CAD documents, including assembly validation property.
- Multi-identifications attributes transfer through a full loop test between two PDM systems.

Since PLM vendors and CAD integrators constantly enhance the functionalities and robustness of their STEP AP242 interfaces, the results of this Benchmark provide a snapshot of the functionalities tested at a certain moment in time for a specific version of the vendors' solutions. New editions of this Benchmark report will be published, addressing additional software & functionalities.

2 References and terms

2.1 Reference documents

Name	Status version	Link
Recommended Practices for STEP AP242 BO Model XML Product and Assembly Structure	Release 2.0.5	www.pdm-if.org
STEP AP242 Edition 1 BO Model Schema TC1	IS Ed1 TC1 (10303-3001 Ed2)	https://standards.iso.org/iso/10303/-3001/-ed-2/tech/xml-schema/bo_model/
Reference sample files (two STEP datasets)	2019 December PDM-IF version	http://private.pdm-if.org

Table 1 – Reference documents

2.2 Abbreviations

AVP	Assembly Validation properties
BO Model	AP242 Business Object Model of (ISO 10303-3001)
CAD	Computer-aided design
CAX-IF	CAX Implementor Forum
centroid VP	Assembly Notional Centroid Validation Property
COTS	Commercial off-the-shelf
PDM	Product Data Management
PDM-IF	PDM Implementor Forum
IS	International Standard
ISO	International Organization for Standardization
LTA	Long-term archiving
nb. child. VP	Assembly Number of Children Validation Property
PDF	Portable Document Format (ISO 32000)
3D PDF	3D viewer format defined by PDF/E (ISO 24517)
PLM	Product Lifecycle Management
Part 21	ISO 10303-21
R.P.	Recommend Practices
STEP	Standard for the Exchange of Product model data
STEP AP242	Application protocol: Managed model-based 3D engineering (ISO10303-242:2014)
VP	Validation Property
XML	Extensible Mark-up Language
XSD	XML Schema Definition

3 Test methodology

This document describes the suite of test cases to be used by the PDM work package of the STEP AP242 Benchmark #3. The Benchmark concentrates primarily on testing the interoperability and compliance of STEP processors based on AP242.

The test model dataset, the procedure and the test criteria are based on the PDM Implementor Forum project.

3.1 Functionalities tested in this benchmark

In this benchmark the two test cases, “*NEST*” and “*Multi-Ids*”, are tested. The core capabilities are export and import of STEP dataset to and from PDM Systems using AP242 BO Model XML, with focus on:

- Completeness of the product structure;
- Completeness and correct positioning of the assembly;
- Transfer of PDM-specific attributes, with focus on multi-identification attributes and assembly validation properties.

The tested capabilities are separated in independent test cases and therefor described in specific chapters:

- 4 Test case NEST: PDM Assembly with 3D Geometry represented with nested files;
- 5 Test case Multi-Ids.

As this benchmark contains two test cases, please refer to the testing procedure and criteria in the related chapter.

3.2 List of tested solutions

This section describes the list of tested applications during this Benchmark. The selection of applications has been done according to:

- the needs of industry representatives supporting the Benchmark,
- the availability of resources and funding;
- the availability of COTS tools according to the tests planning;
- the commitment of the support of PLM vendors to the Benchmark.

The list of test solutions and their descriptions (type of application, version, target PDM system, etc.) are included in the Benchmark report.

4 Test case *NEST*: PDM Assembly with 3D Geometry represented with nested files

4.1 “Nested” / “fully shattered” approach

The aim of this test case is to extend the scope of the base model by using the “nested” or “fully shattered” approach, i.e. creating one XML file per level in the assembly structure plus one per leaf node part. The figures on the next clause shows the file structure.

The specific difference in this test case is that the assembly information is no longer contained in a single AP242 BO Model XML file, but there is one for each node in the assembly structure, defining the relationships to its immediate children. In case of the AS1 model, this results in one AP242 BO Model XML file for each level in the assembly structure, plus one per component part including transformations, and finally one geometry file for each of the five component parts, referenced by the XML files. Refer to section 9.2 File Structure (monolithic/nested) in the AP242 Business Object Model XML Assembly Structure Recommended Practices.

It is worthwhile to point out that there are XML files not only for the actual assembly nodes (root and intermediate), but also for the leaf node geometry files. The reason for this can be seen when looking at the *Nut* part: this is referenced from two different subassemblies (*Rod Assembly* and *Nut-Bolt Assembly*). All part-level PDM-relevant attributes will be stored, once, in the *Nut.stpx* file, which will in turn reference the geometry. This part-level XML file is called a “*sidecar file*” because it acts like the sidecar on a motorcycle: following everywhere, carrying additional contents. It is based on the general assumption that the actual leaf node files are “*black boxes*” from the PDM system’s point of view, i.e. the PDM interface cannot extract information from them, hence needs the data in XML format. The alternative would be to duplicate the part-level data for the *Nut* in *rod-assembly.stpx* and *nut-bolt-assembly.stpx*, which introduces redundancy as well as the risk of inconsistencies.

This sidecar XML file will reference all files associated with the respective node, i.e. the CAD file as well as any additional non-CAD documents.

4.2 Test model overview

The following two figures present illustrations of the test model dataset.

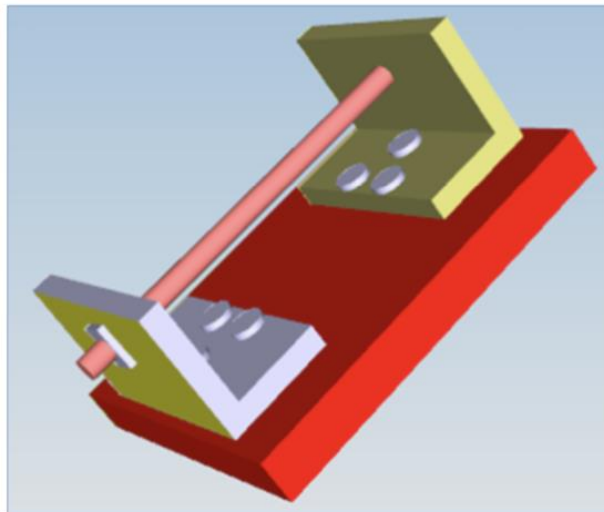

Figure 2 – Illustration of the 3D Geometry of the dataset “AS1”

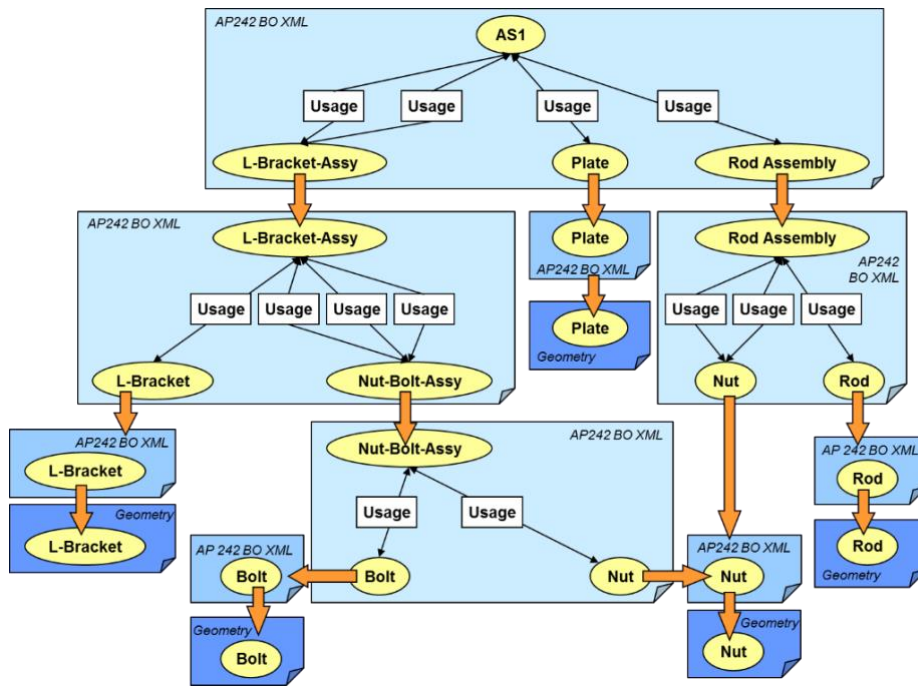

Figure 3 – Example of AS1 for Nested Structure

4.3 Test procedure

The illustration below presents the steps of the procedures. Each of those steps are associated test criteria, which have described in the next clause.

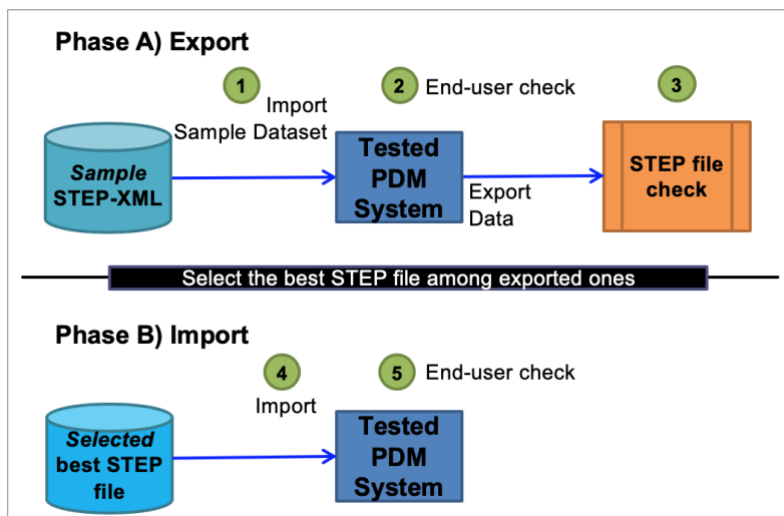

Figure 4 – Test procedure illustration

The selection of best STEP file among exported ones has been done to decrease the test phase workload according to the availability of the resources. A systematic import of a STEP file in each application increases the workload, depending on the number of applications able to create the STEP files, and the quality issues of the STEP files.

The general approach was to select a STEP file of good quality for each functionality tested. Below is the list of selection criteria that need to be fulfilled:

1. no errors listed in the export log files;
2. no major unsuccessful STEP file conformity checks based on the criteria defined in 4.4;
3. loop test successful (import into the exporting system using the same translator).
4. no errors in the validation properties.
5. completeness of critical content.

The document format properties need to be set accordingly, so that it can be easily identified whether the referenced file is another XML structure file, or a geometry file. See the specific PDM representation of a product structure with nested XML file in the Recommended practices.

4.4 Test criteria

The evaluation of the testing is done using the testing criteria in the table below. The following criteria apply for the *NEST* test case in both the exported STEP file and in the PDM/connector systems end-user graphical interface.

Testing for **solutions without target PDM system** are covered and test criteria are described below. Solutions without target PDM system are tested as:

- a PDM data exchange system without PDM application functionalities.
- a PDM to CAD-viewing format converter. The selected target format is 3D PDF (PDF/E ISO Standard) as it meets the industry needs and the test criteria scope.

Table 2 – Test criteria of *NEST* test case:

Step	Criteria name	Criteria description
Phase A: STEP import from sample file and export		
1	STEP IMPORT	STEP IMPORT is supported if the interface imports the dataset from nest STEP XML with all associated geometry files. Import/conversion logs and messages shall be checked for warnings and errors.
2	End-User check	<p>Import the reference STEP model dataset (sample STEP-XML of the PDM-IF) and verify the completeness of imported data in the tested PDM system:</p> <p>Product Structure Assembly Structure; AVP: number of children; AVP: notional solids</p> <p><i>The Assembly Validation Properties import from the STEP file is supported by the import interface if the system provides a report (e.g.: log text) on: imported validation values, values calculated based on imported data, a comparison of the two values, and a derived OK/KO based on a given threshold. The monitoring/displaying of these validation properties values by the PDM system or the interface is optional.</i></p> <p><i>The number of children and notional solids are the only AVPs in scope for this Benchmark.</i></p> <p>Product Master Data and PDM Properties ID; Version; Name/Description; Approval Status; Administrative Data</p>
3	STEP EXPORT	STEP EXPORT is supported if the interface exports the dataset to STEP XML with all associated geometry files. Export/conversion logs and messages shall be checked for warnings and errors.

Step	Criteria name	Criteria description
3	STEP EXPORT Assembly Validation Properties	STEP EXPORT Assembly Validation Properties is supported if the STEP interface computes and writes the AVP in the STEP files. The number of children and notional solids are the only AVPs in scope for this Benchmark.
3	STEP file conformity	Evaluate the quality of the STEP XML file. The 3 following sub-criteria below are part of this STEP file conformity criteria.
3	XML conformity check error	Exported STEP XML file shall be conform to XML standard. No specific tools are imposed.
3	XSD conformity check error	Exported STEP XML file shall be conform to the ISO 10303-3001 XSD. No specific tools are imposed.
3	Recommended practices conformity check and Compare to original AP242 XML Sample File	<p>Exported STEP XML file shall be conform to the business rules defined in the CAx-IF Product and Assembly structure Recommended practice referenced in clause 2.1.</p> <p>Exported STEP XML is compared with the Reference sample XML file of the PDM-IF using an XML comparator tool. No specific tools are imposed. All differences are listed and analysed in order to determine the severity of the difference. Two levels of severity are used: "Noncritical" and "Critical". Here "critical" means that the spotted data difference is evaluated to most probably lead to a bad interpretation or non-consumption of the data by the target system. Three types of comparison results are used: un-expected data, missing data and additional data.</p> <p>Important note: It has been decided to merge the results of the Recommended Practices conformity check result with the comparison to original AP242 XML Sample file. This decision was taken because the comparison results were already reported by the Recommended Practices results. During this benchmark, no fatal non-consumption of the data by the target system was detected. So these checks do not provide new insights. Moreover, comparison to original AP242 Sample file check do not reflect real-world scenarios where there is not sample file to compare against. This decision is taken for the future editions of the benchmark.</p>
Phase B: STEP import from selected files		
4	STEP IMPORT	Same as above (Step 1)
5	End-User check	Same as above (Step 2)
Same as above but by solution without target PDM systems		
6	STEP IMPORT	When applicable depending of the solution type, same as step 1.
7	End-User check	When applicable depending of the solution type, same as step 2.
8	STEP EXPORT	When applicable depending of the solution type, same as step 3.
9	3D PDF EXPORT	Export log and visual check of the 3D Geometry
10	AVP, GVP, PDM attributes and product structure presentation	The end user check of the in-scope AVP value, in-scope PDM attributes and the product structure of the test model.
11	AVP and GVP checks	The Assembly and Geometry Validation Properties import from the STEP file is supported by the import interface if the system provides a report (e.g.: log text) on: imported validation values, values calculated based on imported data, a comparison of the two values, and a derived OK/KO based on a given threshold.

5 Test case *Multi-Ids*

5.1 Multi-Ids approach

This test case describes the use of the “toy block car” dataset as new geometry model for the exchange of multiple identification attributes, set by different organization’s PDM systems.

It covers the following scenarios:

- Update sending of data as well as return sending of data.
- Requires management of common part IDs at OEM and supplier, independently from the local IDs at OEM and supplier side.

OEM and supplier’s systems are described and illustrated in clause 5.3.

This test case introduces a new way to manage the identification information using the Identifier with his role and context. A class has been created in the Sample STEP-XML to specify which information have to be preserved by the STEP interface:

```
<Class uid="rl--eii">
  <Id id="exchange identification information"/>
</Class>
```

Multiple IDs are applied **only** for the Part.ID. See example below:

```
<Part uid="p--0000000065FEB00">
  <Id>
    <Identifier id="PONPDG5" idContextRef="org--0xbc66cf8" idRoleRef="rl--ii" uid="pid--0000000065FEB00--id1"/>
    <Identifier id="PONPDG5 PDM-IF" idContextRef="0_603823" idRoleRef="rl--eii" uid="I_603824"/>
  </Id>
  <Name>
    <CharacterString>A 1 A ST PACKAG, ROOT ST AUTO, PRJA </CharacterString>
  </Name>
  <PartTypes>
    <ClassString>assembly</ClassString>
  </PartTypes>
  <Versions>
    <PartVersion uid="pv--0000000065FEB00--id1">
      <Description>
        <CharacterString>PONPDG5 A 1 A ST PACKAG, ROOT ST AUTO, PRJA desc</CharacterString>
      </Description>
    </PartVersion>
  </Versions>
</Part>
```

The following Part identifiers shall be provided by the **supplier**:

- **(mandatory)** PDM-IF identifier (with idContextRef defined as following and idRoleRef = ‘exchange identification information’):

```
<Organization uid="0_603823">
  <Id id="PDM-IF"/>
  <Name>
    <CharacterString>PDM-IF</CharacterString>
  </Name>
</Organization>
```

- **(optional)** own identifier (with own organization as idContextRef and idRoleRef = ‘identification information’).

The following changes shall be made by the **OEM**:

- Set the Life Cycle Status of all parts to ‘approved’.

The following Part identifiers shall be provided by the OEM:

- **(mandatory)** original PDM-IF identifier (with idContextRef defined as following and idRoleRef = 'exchange identification information');

```
<Organization uid="0_603823">
  <Id id="PDM-IF"/>
  <Name>
    <CharacterString>PDM-IF</CharacterString>
  </Name>
</Organization>
```

- **(optional)** own identifier (with own organization as idContextRef and idRoleRef = 'identification information');
- **(optional)** original supplier identifier (with original supplier organization as idContextRef and idRoleRef = 'identification information').

In order to test the Full Loop, the changes made by the OEM shall be re-imported on the supplier side.

5.2 Test model overview

The following figure presents an illustration of the test model dataset.

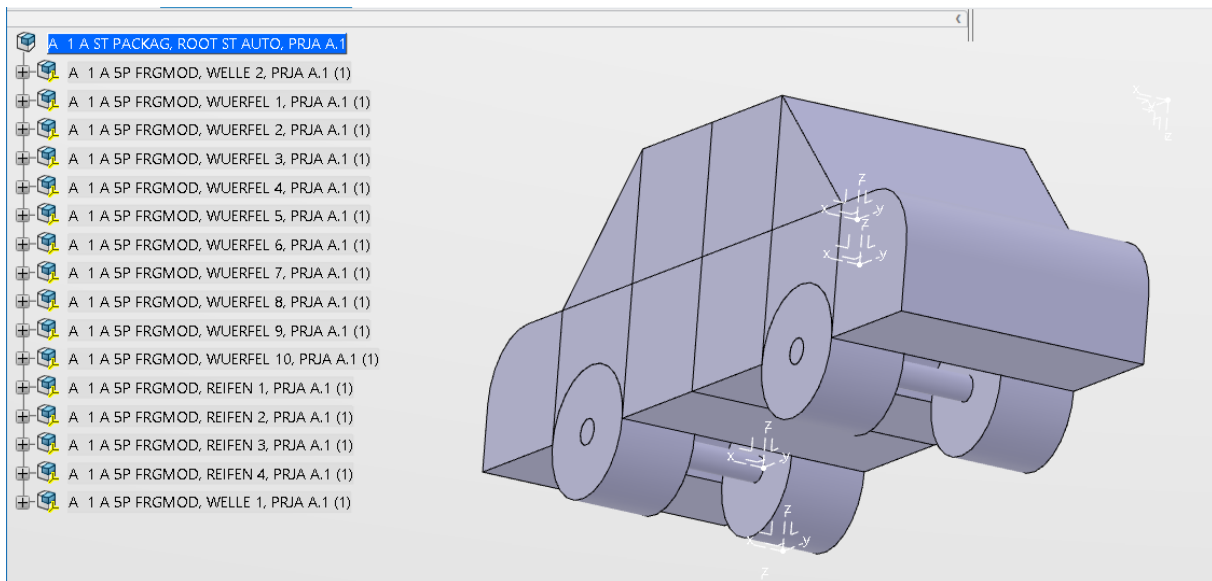

Figure 5 – "Toy car block" Test model illustration

5.3 Test procedure

The PDM System A can be considered the supplier's system. In the test procedure illustration below, it is the system A that is tested. The PDM system B can be considered the OEM's system. Then, the PDM System A is tested as the PDM System B. Please refer to the criteria table for the details of each step.

The most important Id attribute to be transferred is the "Id X", which has the role of exchange information identification. "Id A" is the Id attribute created and assigned by the PDM system A (same for "Id B" respectively), this Id is a *system* Id. These Id attributes ("Id X, A, B") are assigned to all nodes of the assembly.

Depending on the tested solution, the Id A/B are set automatically or by the user. Regarding end user checks, it shall be noted that most of out-of-the box PDM systems do not support multi-ids, therefore the tested solution itself and the STEP file shall be considered to verify the multi-ids support.

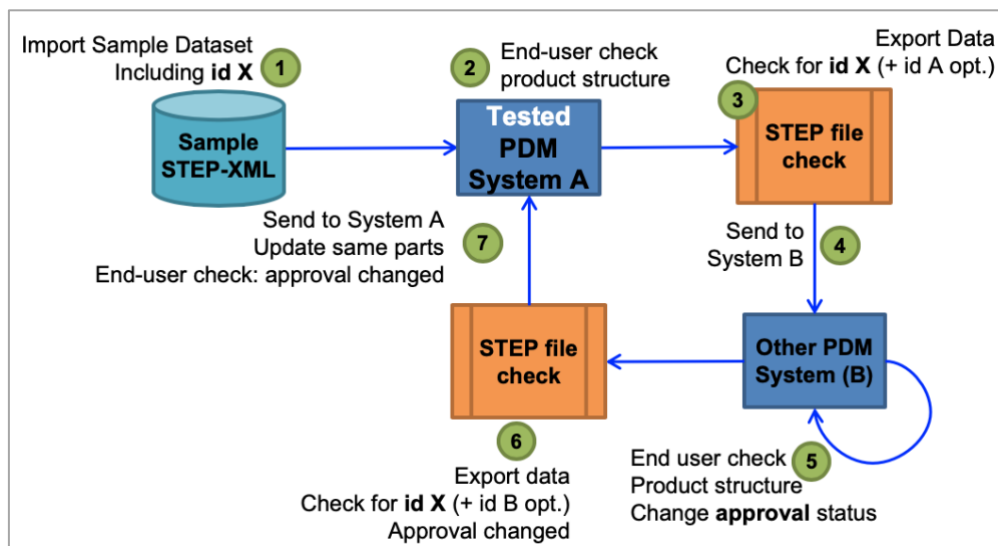

Figure 6 – Test procedure illustration

5.4 Test criteria

The evaluation of the testing is done using the testing criteria in the table below. The following criteria apply for the *Multi-Ids* test case in both the exported STEP file and in the PDM/connector systems end-user graphical interface.

Testing for **solutions without target PDM system** are covered below, as well as test criteria. Solutions without target PDM system are tested as:

- a PDM data exchange system without PDM application functionalities
- a PDM to CAD-viewing format converter. The selected target format is 3D PDF (PDF/E ISO Standard) as it meets the industry needs and the test criteria scope

Table 3 – Test criteria of Multi-Ids test case

Step	Step title	Criteria description
Solution with target PDM system		
1	STEP IMPORT	STEP IMPORT is supported if the interface imports the dataset form nest STEP XML with all associated geometry files. Import/conversion logs and messages shall be checked for warnings and errors.
2	End-User check	Import the reference STEP model dataset and verify the completeness of imported data in the target PDM system by checking the product structure, relationships, and the main PDM attributes. The following information have to be correct: - Product structure - The approval life cycle status shall not be "Approved" - Id added automatically by PDM A or by the PDM A user (named "A"), but not needed to be seen in the PDM interface.
3	STEP EXPORT	STEP EXPORT is supported if the interface exports the dataset to STEP XML with all associated geometry files. Export/conversion logs and messages shall be checked for warnings and errors. The following information must be correct in the STEP file: - id X - Optional: id A - Approval status shall NOT be "Approved"
3	STEP file conformity	Evaluate the quality of the STEP XML file. The 3 following sub-criteria below are part of this STEP file conformity criteria.
3	XML conformity check error	Exported STEP XML file shall be conform to XML standard. No specific tools are imposed.
3	XSD conformity check error	Exported STEP XML file shall be conform to the ISO 10303-3001 XSD. No specific tools are imposed.

Step	Step title	Criteria description
3	Recommended practices conformity check and Compare to original AP242 XML Sample File	<p>Exported STEP XML file shall be conform to the business rules defined in the CAX-IF Product and Assembly structure Recommended practice referenced in clause 2.1.</p> <p>Exported STEP XML is compared with the Reference sample XML file of the PDM-IF using an XML comparator tool. No specific tools are imposed. All differences are listed and analysed in order to determine the severity of the difference. Two levels of severity are used: "Noncritical" and "Critical". Here "critical" means that the spotted data difference is evaluated to most probably lead to a bad interpretation or non-consumption of the data by the target system. Three types of comparison results are used: un-expected data, missing data and additional data.</p> <p>Important note: It has been decided to merge the results of the Recommended Practices conformity check result with the comparison to original AP242 XML Sample file. This decision was taken because the comparison results were already reported by the Recommended Practices results. During this benchmark, no fatal non-consumption of the data by the target system was detected. So these checks do not provide new insights. Moreover, comparison to original AP242 Sample file check do not reflect real-world scenarios where there is not sample file to compare against. This decision is taken for the future editions of the benchmark.</p>
4	STEP IMPORT	The exported file is now imported in PDM System B. Checks are made as in step 1. <u>As system B is not the tested solution, all the criteria depending on system B functionalities, will not impact system A results.</u>
5	Approval, End-User check	<p>The imported file is checked as in step 2, but:</p> <p><u>The tested PDM A is now considered as the "Other PDM system (B)":</u> The Approval status shall be changed to "approved".</p> <p><u>The imported STEP file will be from another PDM system/interface solution and will not affect the tested solution criteria results.</u></p>
6	STEP EXPORT	<p>STEP EXPORT is supported if the interface exports the dataset to STEP XML with all associated geometry files. Export/conversion logs and messages shall be checked for warnings and errors.</p> <p>The following information must be correct in the STEP file:</p> <ul style="list-style-type: none"> - id X - Optional: id B - Approval status shall be equal to "Approved"
7	STEP IMPORT	<p>STEP IMPORT is supported if the interface imports the dataset form nest STEP XML with all associated geometry files. Import/conversion logs and messages shall be checked for warnings and errors.</p> <p>The following information must be correct in the PDM system:</p> <ul style="list-style-type: none"> - Product structure - Approval status shall be equal to "Approved" - The same parts in step 2 are updated by this new import, meaning that the interface recognized the initial "id X"

Step	Step title	Criteria description
Solution without target PDM systems		
3DPDF	STEP to 3DPDF conversion quality	STEP to 3DPDF conversion quality is supported if: <ul style="list-style-type: none"> - the interface imports the dataset form STEP XML with all associated geometry files - Import/conversion logs and messages shall be checked for warnings and errors - 3D Geometry - Product structure - Optional: id X - Approval status
No PDM application functionalities	STEP Import, visualize, export	STEP IMPORT is supported if the interface imports the dataset form STEP XML with all associated geometry files. Import/conversion logs and messages shall be checked for warnings and errors. <p>The following information must be correct in the tested application:</p> <ul style="list-style-type: none"> - 3D Geometry - Product structure - Optional: id X - Approval status STEP EXPORT is supported if the interface exports the dataset to STEP XML with all associated geometry files. Export/conversion logs and messages shall be checked for warnings and errors. <p>The following information must be correct in the STEP file:</p> <ul style="list-style-type: none"> - id X - Approval status

6 Tested solutions and test results

6.1 Introduction

This chapter present the following contents:

Tested solutions

Tested solutions and tested conversions that are in scope of this benchmark are presented in Table 4 – Tested solution and conversions. It important to refer to this table to know the solution type as considered for this benchmark.

Overview of all tests results

This part is presented using a table with all test criteria and tested solutions. This clause includes two sub-clauses because two test cases are covered: NEST test case results and Multi-id test case results.

The legend of the symbols presented in Table 5 – Legend evolved compared to the previous benchmark because it is necessary to present the level of severity of issues in more detailed as the results are very positive: the new legend is defined below:

- Total success: no issues spotted regarding the test criteria;
- Success with minor issues: the issues are not severe in the meaning that the transfer of data is correctly done, and the quality verification of the data reports no errors;
- Partial success with major issues: spotted issues are evaluated to lead to an incorrect interpretation during the transfer of data and its quality verification;
- Partial success with critical issues: spotted issues are evaluated to lead to non-consumption of the information during the transfer of data and its quality verification reports fatal errors, such as un-expected data or missing data;
- Total fail: spotted issues lead to fatal errors during export, import and checks of the dataset;
- Not supported: the functionality is not supported by the solution;
- Not applicable: no results to provide regarding the solution type.

This legend applies for all results tables in this chapter.

Test results per solutions

This part presents in detail the results for each participating interface. Each of this clause includes two sub-clauses to cover the two test cases. The result test criteria of those clauses depend on the solution types specified in clause 6. The related clauses per solution is not in the public report.

Test results by STEP functionalities and conformity criteria

This part is presented in clause 6.4 and is in of the public report. This chapter present the results, not per solutions, but per STEP functionalities and STEP conformity.

6.2 Tested solutions

Company	Application name	Solution type*	Tested conversion
CT CoreTechnologie	3D_Evolution 4.3 SP1	Converter and viewer (no target PDM system)	STEP AP242 ⇔ 3D_Evolution
Dassault Systèmes	3DEXPERIENCE R2020x FD01	PDM System	3DEXPERIENCE ⇔ STEP AP242
Datakit	CrossManager V2020.1	Converter and viewer (no target PDM system)	STEP AP242 ⇔ 3DPDF
Elysium	ASFALIS EX8.2	Converter and viewer (no target PDM system)	STEP AP242 ⇔ 3DPDF STEP AP242 ⇔ STEP AP242
PROSTEP AG	OpenPDM v8.5.8 for TeamCenter v11.5	PDM system connector	TeamCenter ⇔ STEP AP242
T-Systems	COMPDM v2020.1.0 for Aras Innovator 12.0 SP1	PDM system connector	Aras Innovator ⇔ STEP AP242

* As considered for this benchmark.

Table 4 – Tested solution and conversions

Test result	Symbol
Total success	●
Success with minor issues	◐
Partial success with major issues	◑
Partial success with critical issues	◒
Total fail	●
Not supported	
Not applicable	n/a

Table 5 – Legend

6.3 Overview of all tests results

6.3.1 NEST test case results

Step number	Criteria name	Solution with target PDM system (end-user check is done in the PDM system)			Solution without target PDM system (end-user check is done in 3DPDF or in the solutions)		
		Dassault Systèmes 3DEXPERIENCE R2020x FD01	PROSTEP AG OpenPDM v8.5.8 for TeamCenter v11.5	T-Systems COMPDM v2020.1.0 for Aras Innovator 12.0 SP1	Datakit CrossManager 2020.1	Elysium ASFALIS EX8.2	CoreTechnologie 3D_Evolution 4.3 SP1
Phase A: STEP import from sample file and export							
1	STEP IMPORT	●	●	●	●	●	●
2	End-user check	●	●	●	●	●	●
	End-user check of nb. child. VP	●	●	●	●		●
	End-user check of centroid VP	●			●		●
3	STEP EXPORT	●	●	●	n/a	●	●
3	Export of number of children VP	●	●	●	n/a	●	●
	Export of notional centroid VP	●			n/a	●	●
3	STEP file conformity	see the three lines below					
3	XML conformity check error	●	●	●	n/a	●	◐
3	XSD conformity check error	●	●	●	n/a	●	●
3	Comparison and R.P. conformity check	●	◐	●	n/a	◐	●
3	Import of exported STEP File	●	●	●	●	●	●
Phase B: STEP import from selected files							
4	STEP IMPORT	●	●	●	●	●	●
2	End-user check	●	●	●	●	●	●
	End-user check of nb. child. VP	●	●	●	●		●
	End-user check of centroid VP	●			●		●

Table 6 – Summary of the test results for the NEST test case

Test result	Symbol
Total success	●
Success with minor issues	◐
Partial success with major issues	◑
Partial success with critical issues	◒
Total fail	○
Not supported	
Not applicable	n/a

Table 7 – Legend

6.3.2 Multi-id test case results

Step number	Criteria name	Solution with target PDM system (end-user check is done in the PDM system)			Solution without target PDM system (end-user check is done in 3DPDF or in the solutions)		
		Dassault Systèmes 3DEXPERIENCE R2020x FD01	PROSTEP AG OpenPDM v8.5.8 for TeamCenter v11.5	T-Systems COMPDM v2020.1.0 for Aras Innovator 12.0 SP1	Datakit CrossManager 2020.1	Elysium ASFALIS EX8.2	CoreTechnologie 3D_Evolution 4.3 SP1
Phase A: STEP import from sample file and export							
1	STEP IMPORT	●	●	●	●	●	●
2	End-User check	●	●	●	●	●	●
3	STEP EXPORT	●	●	●	n/a	●	●
3	STEP file conformity	see the three lines below					
3	XML conformity check error	●	●	●	n/a	●	●
3	XSD conformity check error	●	●	●	n/a	●	●
3	Comparison and R.P. conformity check	●	◐	●	n/a	◐	●
4	Import of exported STEP File	●	●	●	n/a	●	●
Phase B: STEP import from selected files							
4	STEP IMPORT	●	●	●	●	●	●
5	Approval, End-User check	●	●	●	●	●	●
6	STEP IMPORT	●	●	●	●	●	●
7	STEP EXPORT	●	●	●	n/a	●	●

Table 8 – Summary of the test results for the Multi-id test case

6.4 Test results by functionalities and by STEP conformity criteria

6.4.1 STEP functionalities

The intention of this Benchmark is not only to give an assessment of individual software tools, but also to derive a statement concerning the general maturity of STEP AP242 based implementations.

The test results are grouped by functionality. This helps the reader to answer general questions such as *“how good does the transfer of relevant information work overall?”*.

The results are grouped together so that it provides an overall assessment of the state of the art for STEP interfaces. It also enables to reflect the main criteria implementation maturity.

6.4.2 STEP conformity

The test results will be combined to provide a rating of STEP and XML conformity. This renders a rating of the quality of the implementation and the conformity of the exchanged dataset, rather than the quality of the data exchange.

This section will provide the implementation quality's overall statement of the tested AP242 XML interfaces. The following criteria is be evaluated,

- STEP Export: XML conformity (syntax), XSD conformity (data model and associated rules, cardinalities, values, etc.);
- Recommended Practices conformity.

6.4.3 Conclusion

The overall results of the tested solutions are excellent in terms of support of the STEP AP242 standard in PDM to PDM exchange scenarios. Compared to the Benchmark edition #2 (see Figure 7 – Charts of the test results by STEP functionalities and conformity criteria of the previous benchmark and Figure 8 – Charts of the test results by STEP functionalities and conformity criteria of this benchmark), more functionalities are supported and the files were exchanged between the different solutions with almost no issues. But some AVP features are not supported and the Recommended Practices checks show few not respected rules. All in all, mostly minor issues are found and by communicating it to the editors, they will be able to fix issues in their next releases.

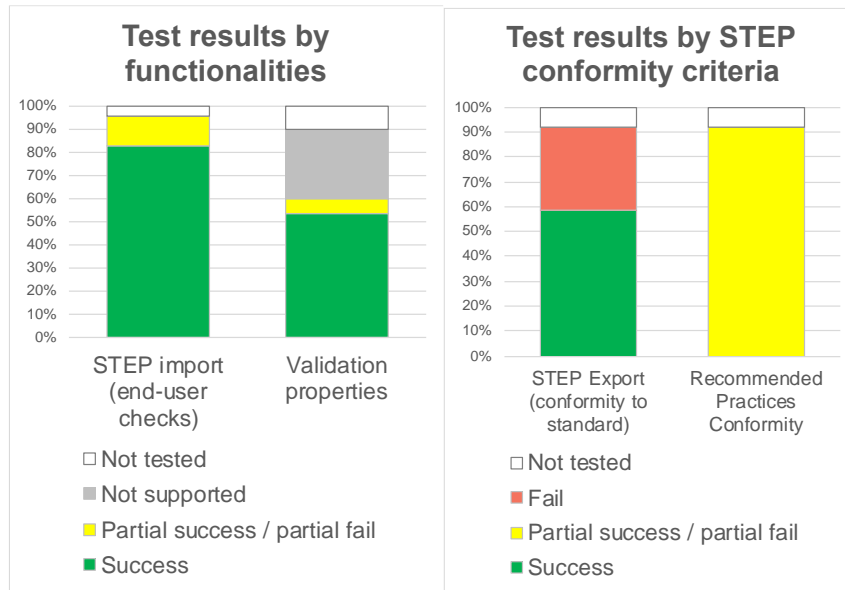

Figure 7 – Charts of the test results by STEP functionalities and conformity criteria of the previous benchmark

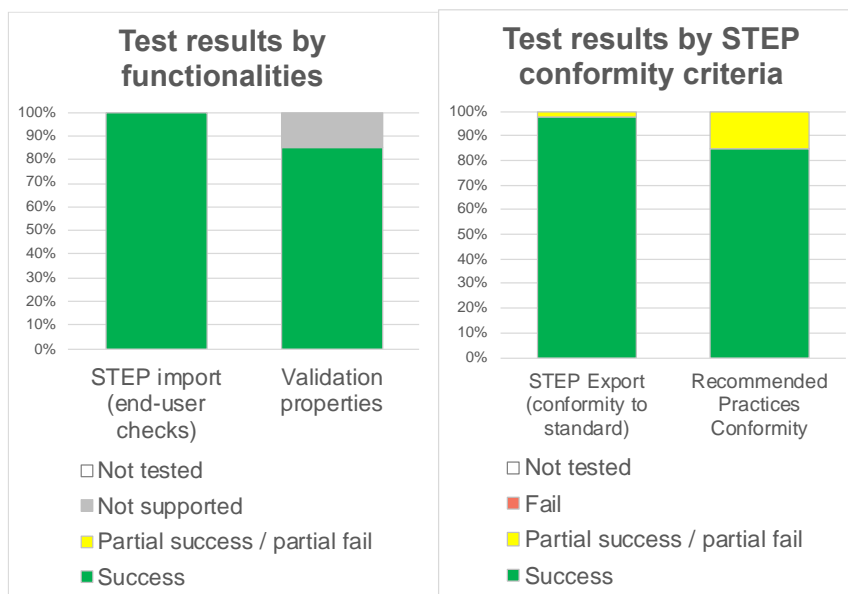

Figure 8 – Charts of the test results by STEP functionalities and conformity criteria of this benchmark

7 Summary

The objectives of the industry are reached only when COTS STEP AP242 applications are available and used by a broad community, with the appropriate level of functionalities and quality.

The level of quality of STEP AP242 XML implementations for PDM product structure exchange has been greatly improved since the previous benchmark. Most of in-scope PDM functionalities are robustly supported. Nevertheless, the assembly validation properties functionality is missing from some solutions. The standard conformity of the produced STEP datasets is nearly perfect. The AFNeT and prostep ivip PDM Implementor Forum (PDM-IF) has contributed to significantly improve the recommended practices compliance. In addition, other outcomes will be provided for the development and for requirements of the edition 3.

The use of international open standards for 3D Model Based interoperability is seen as a key enabler to support global engineering and manufacturing of complex products within the extended enterprise. It also contributes to ensure a better independence regarding PLM vendor's proprietary formats, and long-term preservation of 3D Model Based design. The availability of COTS STEP AP242 solutions for PDM data interoperability contributes to address this challenge.

The present Benchmark provides the status of COTS STEP AP242 converters and viewers in early 2020. The versions of these applications, which will be released in late 2020, provide important enhancements. Their testing will be completed by next benchmark editions. Moreover, next benchmark editions will address additional software and functionality, especially regarding the Edition 2 of AP242 published in early 2020, which includes enhancements and new capabilities.

8 Publications

The detailed documentation of the PDM and CAD test cases in STEP AP242 Benchmarks is only available for the participating Vendors & Industrials of the AFNeT and prostep ivip associations, and is accessible from the following websites:

- <http://www.afnet.fr/dotank/sps/ap242benchmark/>
- <http://www.prostep.org/en/medialibrary/publications/benchmarks.html>

Short Reports are publicly available on <http://benchmark.ap242.org>.

9 Acknowledgements

The AFNeT association and the prostep ivip association thank the applications Vendors who provided their COTS solutions for the Benchmark testing, for their support in the installation, and for the analysis of the test results.

The AFNeT association and the prostep ivip association thank the CAx Interoperability Forum and the PDM Implementor Forum for the STEP Recommended Practices and the test cases. We also thank the participating Vendors, GIFAS, PFA, for their funding and orientations.